



Norwolf Tool Works, Inc.

6 Sullivan Street, Westwood, NJ 07675

Telephone: (201)666-6655

Fax: (201)666-7611

www.norwolf.com

CTC SERIES

XCELINK™

TORQUE MULTIPLIER

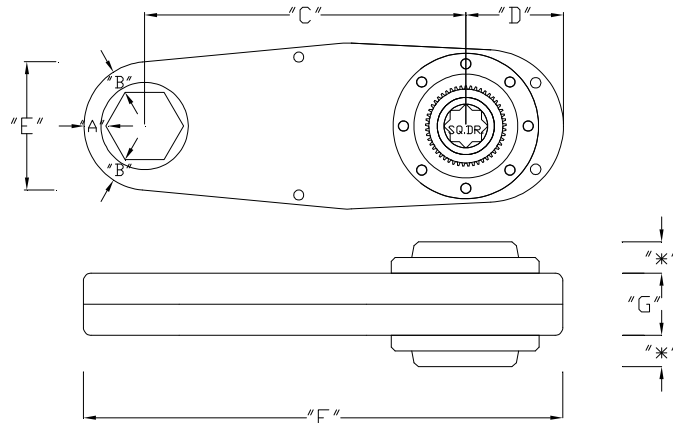
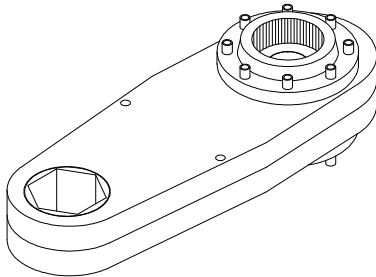

XCELINK™, CONSTANT ROTATION, SPLINED HUB REACTION

XCELINK 3/4" DRIVE, 3:1 RATIO								
MAXIMUM TORQUE: 850 FT. LBS. INPUT / 2550 FT. LBS. OUTPUT								
PART NO.	HEX	"A"	"B"	"C"	"D"	"E"	"F"	"G"
CTC-075-3-1-087-H	7/8"	.461"	.505"	6.13"	2.35"	1.93"	9.44"	1.5"
CTC-075-3-1-106-H	1-1/16"	.461"	.505"	6.13"	2.35"	2.15"	9.55"	1.5"
CTC-075-3-1-125-H	1-1/4"	.461"	.505"	6.13"	2.35"	2.36"	9.66"	1.5"
CTC-075-3-1-143-H	1-7/16"	.461"	.505"	6.13"	2.35"	2.58"	9.77"	1.5"
CTC-075-3-1-162-H	1-5/8"	.461"	.505"	6.13"	2.35"	2.80"	9.88"	1.5"
CTC-075-3-1-181-H	1-13/16"	.461"	.505"	6.13"	2.35"	3.01"	9.98"	1.5"
CTC-075-3-1-200-H	2"	.461"	.505"	6.13"	2.35"	3.23"	10.09"	1.5"
CTC-075-3-1-218-H	2-3/16"	.461"	.505"	6.13"	2.35"	3.45"	10.20"	1.5"
CTC-075-3-1-237-H	2-3/8"	.461"	.505"	6.13"	2.35"	3.66"	10.31"	1.5"
CTC-075-3-1-256-H	2-9/16"	.461"	.505"	6.13"	2.35"	3.88"	10.42"	1.5"
CTC-075-3-1-275-H	2-3/4"	.461"	.505"	6.13"	2.35"	4.10"	10.52"	1.5"
CTC-075-3-1-293-H	2-15/16"	.461"	.505"	6.13"	2.35"	4.31"	10.63"	1.5"
CTC-075-3-1-312-H	3-1/8"	.461"	.505"	6.13"	2.35"	4.53"	10.74"	1.5"

XCELINK 3/4" DRIVE, 4:1 RATIO								
MAXIMUM TORQUE: 850 FT. LBS. INPUT / 3400 FT. LBS. OUTPUT								
PART NO.	HEX	"A"	"B"	"C"	"D"	"E"	"F"	"G"
CTC-075-4-1-087-H	7/8"	.521"	.566"	7.73"	2.35"	2.05"	11.10"	1.5"
CTC-075-4-1-106-H	1-1/16"	.521"	.566"	7.73"	2.35"	2.27"	11.21"	1.5"
CTC-075-4-1-125-H	1-1/4"	.521"	.566"	7.73"	2.35"	2.48"	11.32"	1.5"
CTC-075-4-1-143-H	1-7/16"	.521"	.566"	7.73"	2.35"	2.70"	11.43"	1.5"
CTC-075-4-1-162-H	1-5/8"	.521"	.566"	7.73"	2.35"	2.92"	11.54"	1.5"
CTC-075-4-1-181-H	1-13/16"	.521"	.566"	7.73"	2.35"	3.13"	11.64"	1.5"
CTC-075-4-1-200-H	2"	.521"	.566"	7.73"	2.35"	3.35"	11.75"	1.5"
CTC-075-4-1-218-H	2-3/16"	.521"	.566"	7.73"	2.35"	3.57"	11.86"	1.5"
CTC-075-4-1-237-H	2-3/8"	.521"	.566"	7.73"	2.35"	3.78"	11.97"	1.5"
CTC-075-4-1-256-H	2-9/16"	.521"	.566"	7.73"	2.35"	4"	12.08"	1.5"
CTC-075-4-1-275-H	2-3/4"	.521"	.566"	7.73"	2.35"	4.22"	12.18"	1.5"
CTC-075-4-1-293-H	2-15/16"	.521"	.566"	7.73"	2.35"	4.43"	12.29"	1.5"
CTC-075-4-1-312-S	3-1/8"	.521"	.566"	7.73"	2.35"	4.65"	12.40"	1.5"

XCELINK, 1" DRIVE, 3:1 RATIO								
MAXIMUM TORQUE: 1800 FT. LBS. INPUT / 5400 FT. LBS. OUTPUT								
PART NO.	HEX	"A"	"B"	"C"	"D"	"E"	"F"	"G"
CTC-100-3-1-200-H	2"	.614"	.673"	8.17"	3.13"	3.54"	13.07"	2"
CTC-100-3-1-218-H	2-3/16"	.614"	.673"	8.17"	3.13"	3.75"	13.18"	2"
CTC-100-3-1-237-H	2-3/8"	.614"	.673"	8.17"	3.13"	3.97"	13.28"	2"
CTC-100-3-1-256-H	2-9/16"	.614"	.673"	8.17"	3.13"	4.19"	13.39"	2"
CTC-100-3-1-275-H	2-3/4"	.614"	.673"	8.17"	3.13"	4.40"	13.50"	2"
CTC-100-3-1-293-H	2-15/16"	.614"	.673"	8.17"	3.13"	4.62"	13.61"	2"
CTC-100-3-1-312-H	3-1/8"	.614"	.673"	8.17"	3.13"	4.84"	13.72"	2"
CTC-100-3-1-350-H	3-1/2"	.614"	.673"	8.17"	3.13"	5.27"	13.93"	2"
CTC-100-3-1-387-H	3-7/8"	.614"	.673"	8.17"	3.13"	5.70"	14.15"	2"
CTC-100-3-1-425-H	4-1/4"	.614"	.673"	8.17"	3.13"	6.13"	14.37"	2"
CTC-100-3-1-462-H	4-5/8"	.614"	.673"	8.17"	3.13"	6.57"	14.58"	2"

XCELINK, 1" DRIVE, 4:1 RATIO								
MAXIMUM TORQUE: 1800 FT. LBS. INPUT / 7200 FT. LBS. OUTPUT								
PART NO.	HEX	"A"	"B"	"C"	"D"	"E"	"F"	"G"
CTC-100-4-1-200-H	2"	.694"	.754"	10.30"	3.13"	3.70"	15.28"	2"
CTC-100-4-1-218-H	2-3/16"	.694"	.754"	10.30"	3.13"	3.91"	15.39"	2"
CTC-100-4-1-237-H	2-3/8"	.694"	.754"	10.30"	3.13"	4.13"	15.50"	2"
CTC-100-4-1-256-H	2-9/16"	.694"	.754"	10.30"	3.13"	4.35"	15.60"	2"
CTC-100-4-1-275-H	2-3/4"	.694"	.754"	10.30"	3.13"	4.56"	15.71"	2"
CTC-100-4-1-293-H	2-15/16"	.694"	.754"	10.30"	3.13"	4.78"	15.82"	2"
CTC-100-4-1-312-H	3-1/8"	.694"	.754"	10.30"	3.13"	4.99"	15.93"	2"
CTC-100-4-1-350-H	3-1/2"	.694"	.754"	10.30"	3.13"	5.43"	16.15"	2"
CTC-100-4-1-387-H	3-7/8"	.694"	.754"	10.30"	3.13"	5.86"	16.36"	2"
CTC-100-4-1-425-H	4-1/4"	.694"	.754"	10.30"	3.13"	6.29"	16.58"	2"
CTC-100-4-1-462-H	4-5/8"	.694"	.754"	10.30"	3.13"	6.73"	16.79"	2"

“*” This thickness is determined by the input drive.