

# Norwolf Tool Works, Inc.

6 Sullivan Street, Westwood, NJ 07675  
 Telephone: (201)666-6655 Fax: (201)666-7611  
 www.norwolf.com

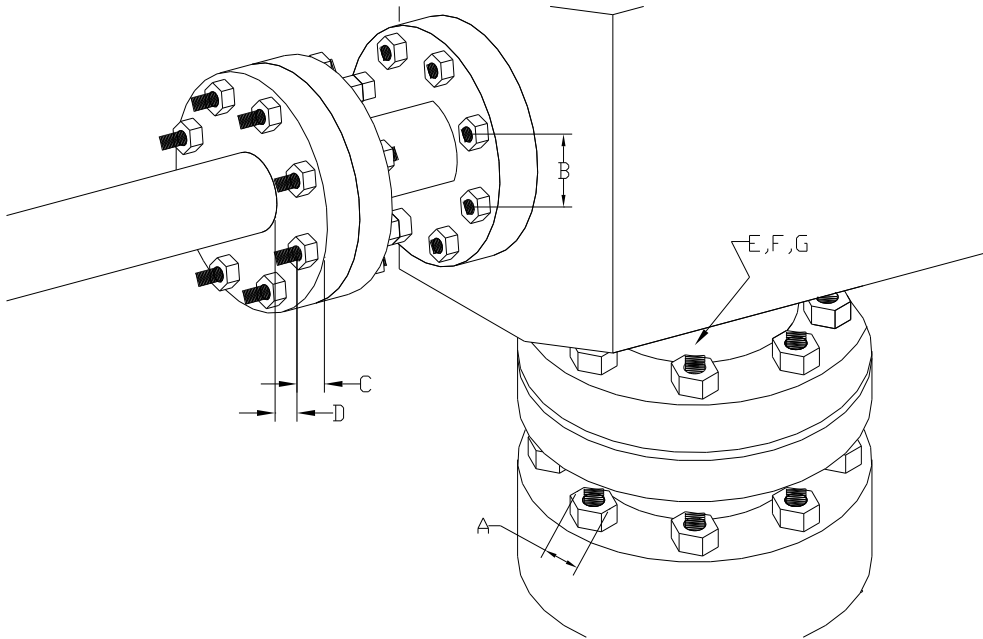

## STANDARD APPLICATION DATA SHEET



- |  |       |
|--|-------|
| A. SIZE OF NUT FROM FLAT TO FLAT         | _____ |
| B. CENTER OF BOLT TO CENTER OF NEXT BOLT | _____ |
| C. CENTER OF BOLT TO EDGE OF FLANGE      | _____ |
| D. CENTER OF BOLT TO INSIDE PIPE         | _____ |
| E. VERTICAL CLEARANCE ABOVE STUD         | _____ |
| F. DIAMETER OF STUD                      | _____ |
| G. LENGTH OF STUD ABOVE NUT              | _____ |
| H. APPROXIMATE TORQUE/TENSION REQ'D      | _____ |

IF APPLICABLE	
	A. WASHER THICKNESS _____
	B. WASHER DIAMETER _____
	C. SPOTFACE DEPTH _____
	D. SPOTFACE DIAMETER _____